

KEOPS V30IM



2x16A /6kW max.

Housing: 2 segment AMAXX[®] - Mennekes

Upstream power supply: single-phase on contactor via terminal block

Downstream single-phase power distribution: 2 sockets 16 A, 2P+E, 230V

The distribution box is available with 2P+E sockets complying with various standards: German, British, Italian, Spanish, etc.

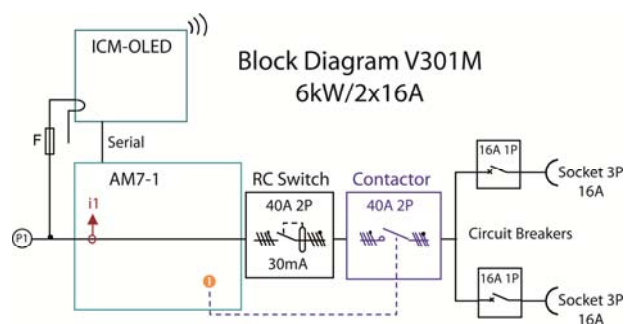

Technical Features

Protection devices:

- Residual current and main switch via residual current switch 40A/30mA, 230V, 2P
- Protection of single phase sockets by 2 x 16A circuit breakers, 230V, 1P or 1P+N*, curve C

Contactor: 1 contactor, 2x230V/ 40A, 2P

Dimensions: (WxHxD) 250x260x170 (excluding handle)

Weight: 4.8kg

Protection index: IP44 with protective glass option on control unit ICM/OLED (IP20 without protective glass)

Standards: complying with standards IEC/EN 60439-1 IEC 60364-1 IEC/EN 60950-1 and CEM 89/336/CEE.

* Depending on earth system and regulations in force in the country concerned