

KEOPS V321MC



Energy counting: 1 energy meter 3x230V, 10 (65) A, official MID

32 A/20 kW max.

Housing: 3 segment AMAXX[®] - Mennekes
Upstream power supply: three-phase on contactor via terminal block

Downstream three-phase power distribution:

1 x 32A P17 socket: P

Downstream single phase power distribution:

3 x 16A sockets: 2P + E 230V

The distribution box is available with 2P + E sockets complying with various standards.

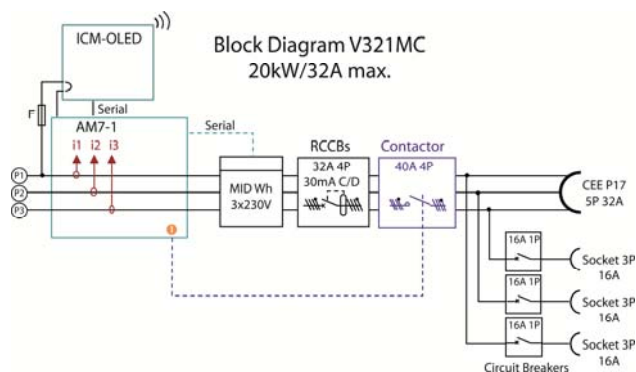

Technical Features

Protection devices:

- Protection of CEE 32A P17 socket and main switch by 32A/30mA residual current circuit breaker, 4P, 400V, C or D curve
- Protection of single phase sockets by 3 x 16A circuit breakers: 230V, 1P or 1P + N*, C curve

Contactor: 1 contactor: 400V, 3P or 4P*, 32A, 20kW AC1

Dimensions: (WxHxD) 250x428x165 (excluding P17 socket and handle)

Weight: 8 kg

Protection index: IP44 with protective glass on control unit ICM/OLED (IP20 without protective glass)

Standards: complying with standards IEC/EN 60439-1, IEC 60364-1, IEC/EN 60950-1 and 89/336/EEC EMC.

* Depending on earth system and regulations in force in the country concerned