

## KEOPS V341R



### 63A /40 kW max.

Housing: polyester KS - RITTAL

Upstream power supply: three phase on contactor via terminal block

Downstream three-phase power distribution:

1x63A CEE/P17 socket, 1x32A CEE/P17 socket, 5 poles

Downstream single phase power distribution: 4x16A, 2P+E 230V sockets, SCHUKO®, one of them is separate for a "fridge socket" running

The distribution box is available with 2P+E sockets complying with various standards: German, Swiss, Italian, Spanish, etc.

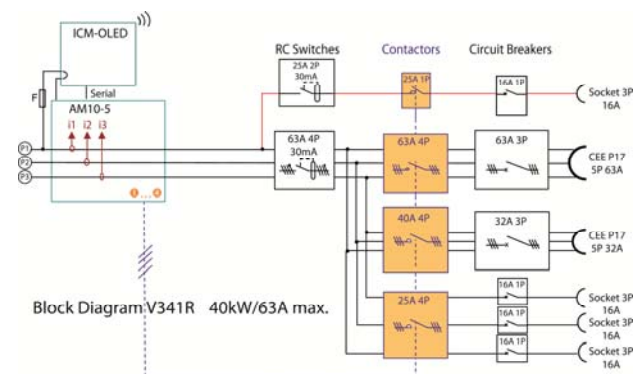

## Technical Features

### Protection devices:

- Residual current protection and main switch (excluding fridge socket) via residual current switch : 63A/30mA, 400V, 4P
- Residual current protection and fridge socket switch via residual current 25A/30mA, 230V,
- Protection of CEE/P17 63A socket by 63A circuit breaker 400V, 3P or 4P\*, C or D curve
- Protection of CEE/P17 32A socket by 32A circuit breaker 400V, 3P or 4P\*, C or D curve
- Protection of single phase sockets by 16A circuit breakers 230V, 1P or 1P+N\*, C curve

### Contactors:

- 1 x 63A contactor 400V, 40kW AC1, 3P or 4P\*, for CEE/P17 63A socket
- 1 x 32A contactor 400V, 20kW AC1, 3P or 4P\*, for CEE/P17 32A socket
- 1 x 25A contactor 230V, 3P or 4P\*, for 3 single phase sockets (excluding fridge socket)
- 1 x 25A contactor 230V, 1P or 1P+N\*, for 16A fridge socket

**Dimensions:** (wxhxd) 300x400x200 (excluding handle and plugs)

**Weight :** 14,3kg

**Protection index:** IP44 with protective glass option on ICM/OLED and circuit breakers. (IP20 without protective glass)

**Standards:** complying with standards IEC/EN 60439-1 IEC 60364-1 IEC/EN 60950-1 and CEM 89/336/CEE.

\* Depending on earth system and regulations in force in the country concerned.